

7786 A Rational Sequence (Take 3)

An infinite full binary tree labeled by positive rational numbers is defined by:

- The label of the root is $1/1$.
- The left child of label p/q is $p/(p+q)$.
- The right child of label p/q is $(p+q)/q$.

The top of the tree is shown in the following figure:

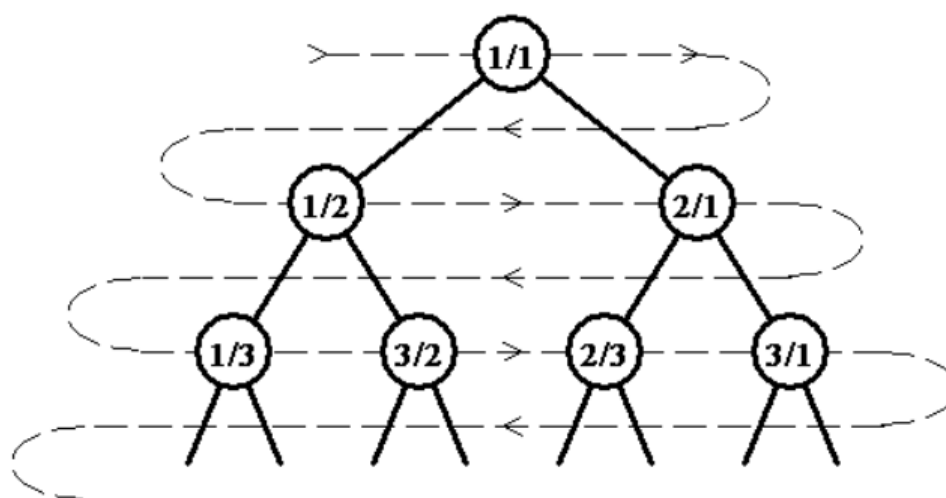

A rational sequence is defined by doing a level order (breadth first) traversal of the tree (indicated by the light dashed line). So that:

$$F(1) = 1/1, F(2) = 1/2, F(3) = 2/1, F(4) = 1/3, F(5) = 3/2, F(6) = 2/3, \dots$$

Write a program to compute the n -th element of the sequence, $F(n)$. Does this problem sound familiar? Well it should! We had variations of this problem at the 2014 and 2015 Greater NY Regionals.

Input

The first line of input contains a single integer P , ($1 \leq P \leq 1000$), which is the number of data sets that follow. Each data set should be processed identically and independently.

Each data set consists of a single line of input. It contains the data set number, K , and the index, N , of the sequence element to compute ($1 \leq N \leq 2147483647$).

Output

For each data set there is a single line of output. It contains the data set number, K , followed by a single space which is then followed by the numerator of the fraction, followed immediately by a forward slash ('/') followed immediately by the denominator of the fraction. Inputs will be chosen so neither the numerator nor the denominator will overflow an 32-bit **unsigned** integer.

Sample Input

```
4
1 1
2 4
3 11
4 1431655765
```

Sample Output

```
1 1/1
2 1/3
3 5/2
4 2178309/1346269
```