

## 7363 A Rational Sequence

A sequence of positive rational numbers is defined as follows:

An infinite full binary tree labeled by positive rational numbers is defined by:

- The label of the root is  $1/1$ .
- The left child of label  $p/q$  is  $p/(p+q)$ .
- The right child of label  $p/q$  is  $(p+q)/q$ .

The top of the tree is shown in the following figure:

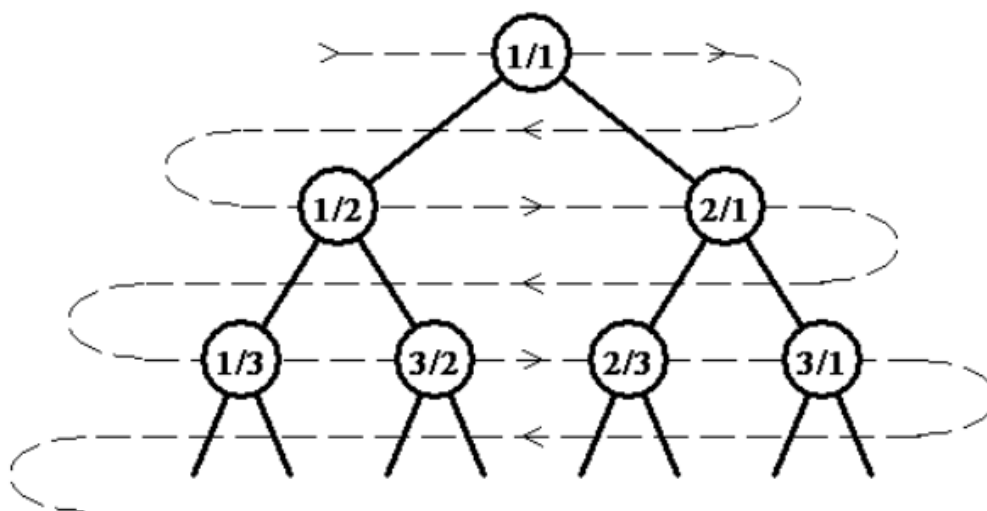

The sequence is defined by doing a level order (breadth first) traversal of the tree (indicated by the light dashed line). So that:

$$F(1) = 1/1, F(2) = 1/2, F(3) = 2/1, F(4) = 1/3, F(5) = 3/2, F(6) = 2/3, \dots$$

Write a program which finds the value of  $n$  for which  $F(n)$  is  $p/q$  for inputs  $p$  and  $q$ .

### Input

The first line of input contains a single integer  $P$ , ( $1 \leq P \leq 1000$ ), which is the number of data sets that follow. Each data set should be processed identically and independently.

Each data set consists of a single line of input. It contains the data set number,  $K$ , a single space, the numerator,  $p$ , a forward slash (/) and the denominator,  $q$ , of the desired fraction.

### Output

For each data set there is a single line of output. It contains the data set number,  $K$ , followed by a single space which is then followed by the value of  $n$  for which  $F(n)$  is  $p/q$ . Inputs will be chosen so  $n$  will fit in a 32-bit integer.

**Sample Input**

```
4
1 1/1
2 1/3
3 5/2
4 2178309/1346269
```

**Sample Output**

```
1 1
2 4
3 11
4 1431655765
```